

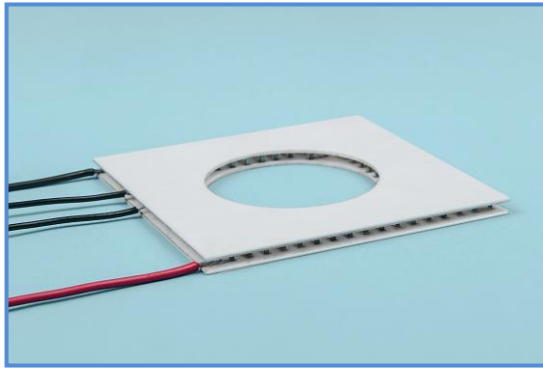

ENGINEERING & PRODUCTION

Thermoelectric Cooling Module

TECB-66-156-1-(14.4-1.2-10)-54-67-CH



Performance specifications		
Hot side temperature Th (°C)	25	50
ΔT_{max} (°C)	67	78
Qmax (Watts)	10	11.1
I _{max} (Amps)	1.2	1.2
V _{max} (Volts)	14.4	16.2
Module resistance (Ohms)	10	12.2

Drawing

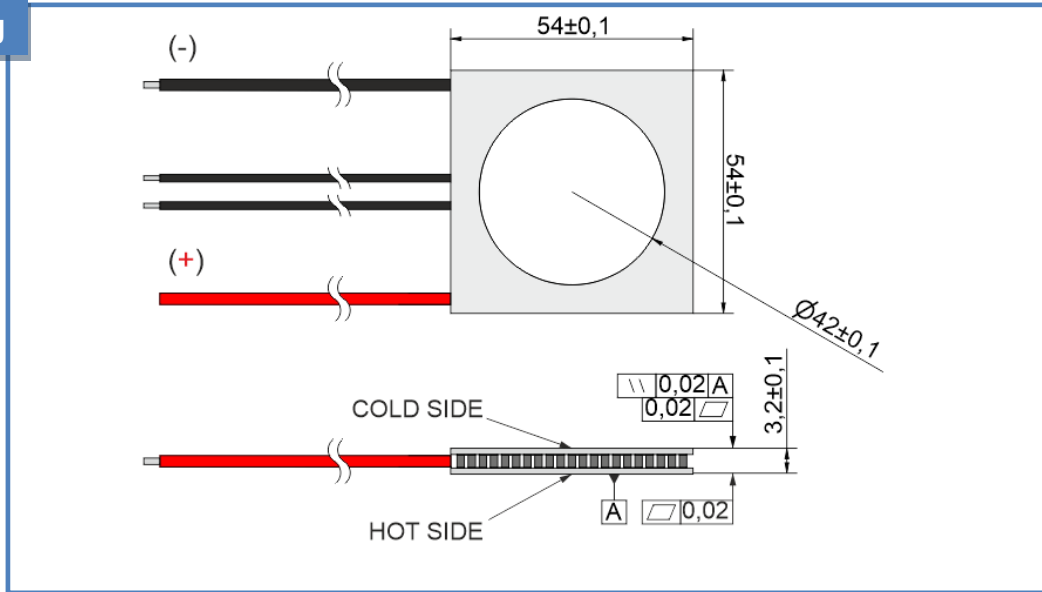

Performance Graphs at Th=25°C

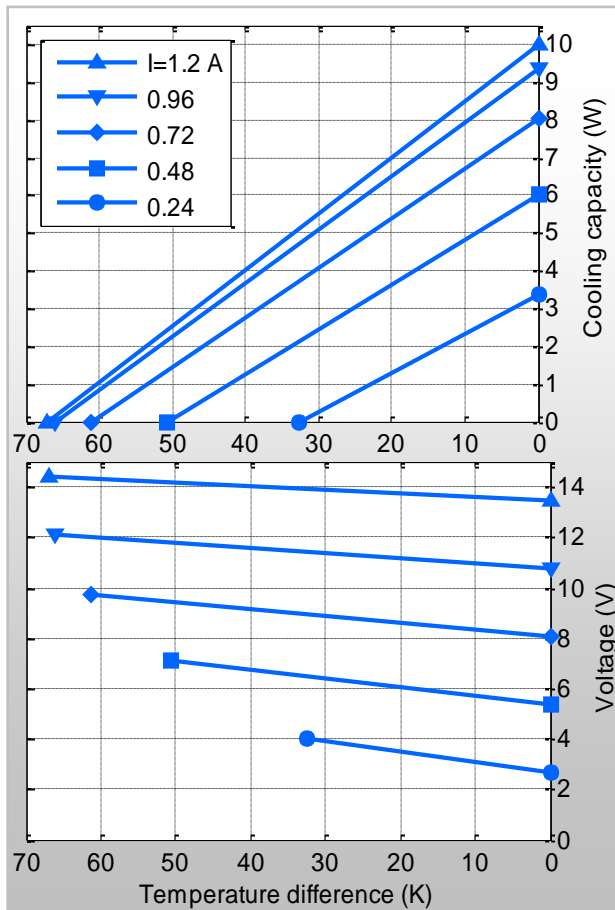

Performance Graphs at Th=50°C

